

Working together for a low-carbon economy

Session 3:

Sectorial Perspectives

Making Energy Efficiency work

in Transport

Willy Tomboy
Environmental Affairs Group
Toyota Motor Europe



**STOP CLIMATE CHANGE:
YOUR CONTRIBUTION COUNTS!**

SUSTAINABLE MOBILITY
SUSTAINABLE MANUFACTURING
SUSTAINABLE RETAIL
SUSTAINABLE SOCIETY

TOYOTA

Three Major Issues towards Zero Emissions

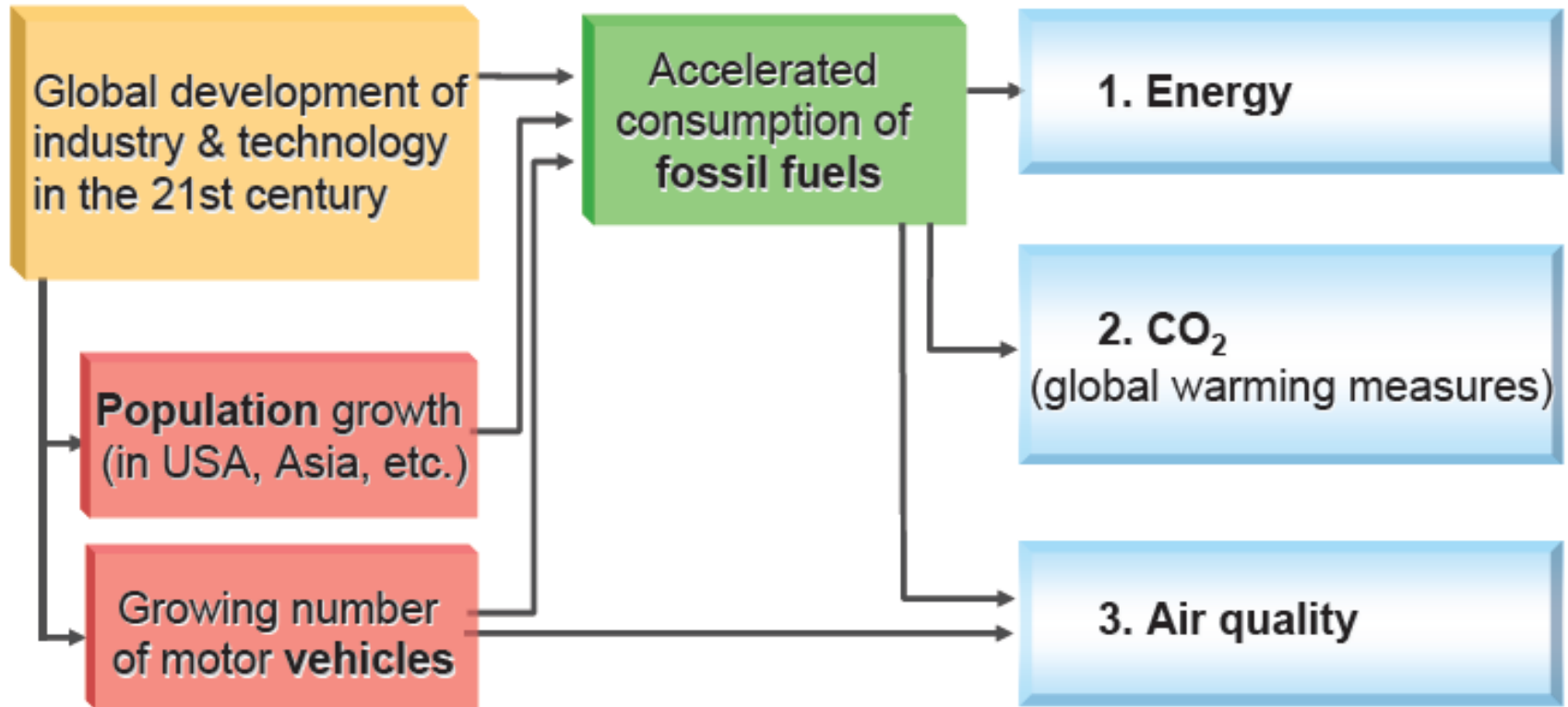

Global increase in vehicles

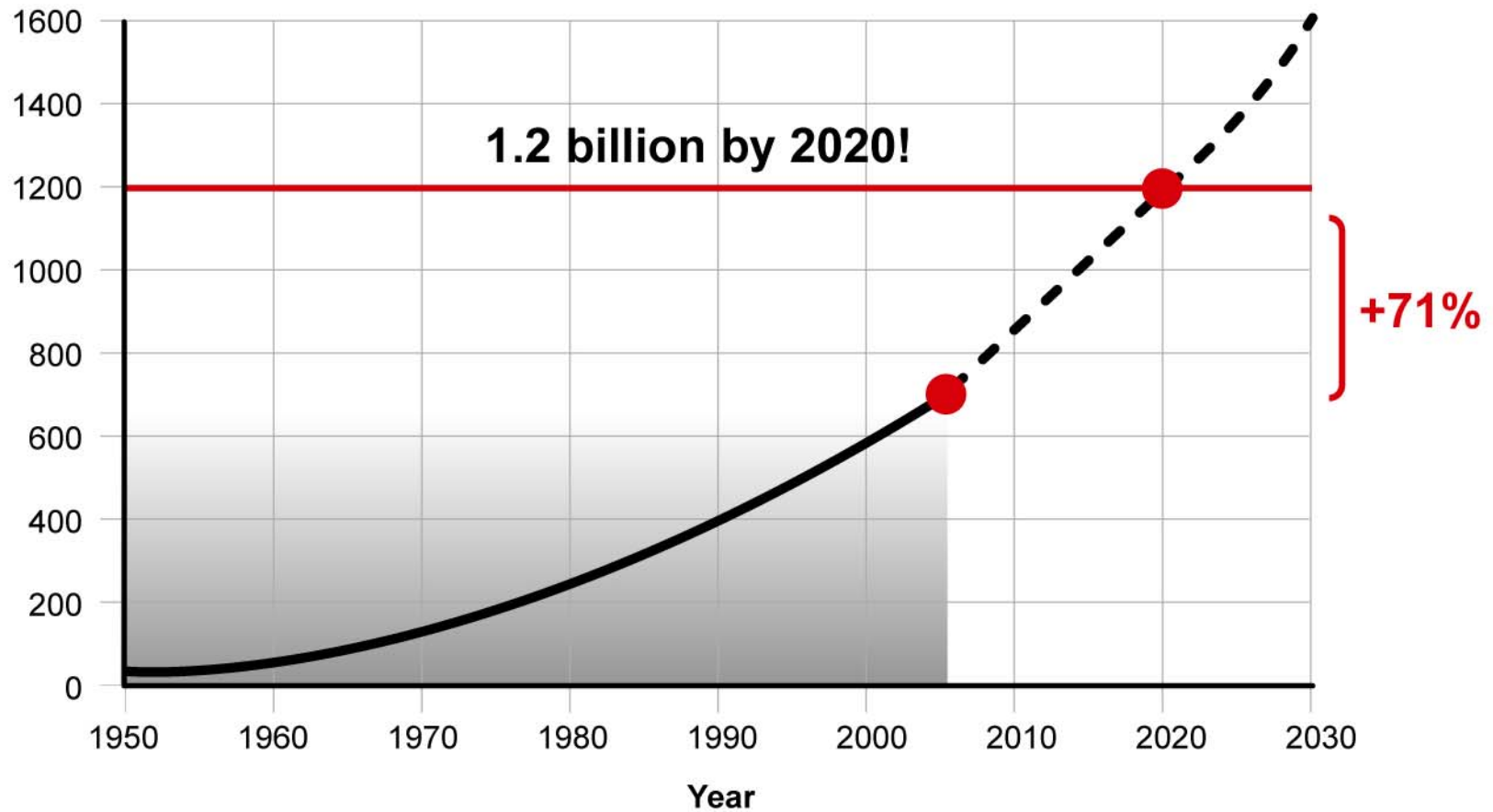

Source: Handbook of automotive industry 1999

CO₂ emissions increase

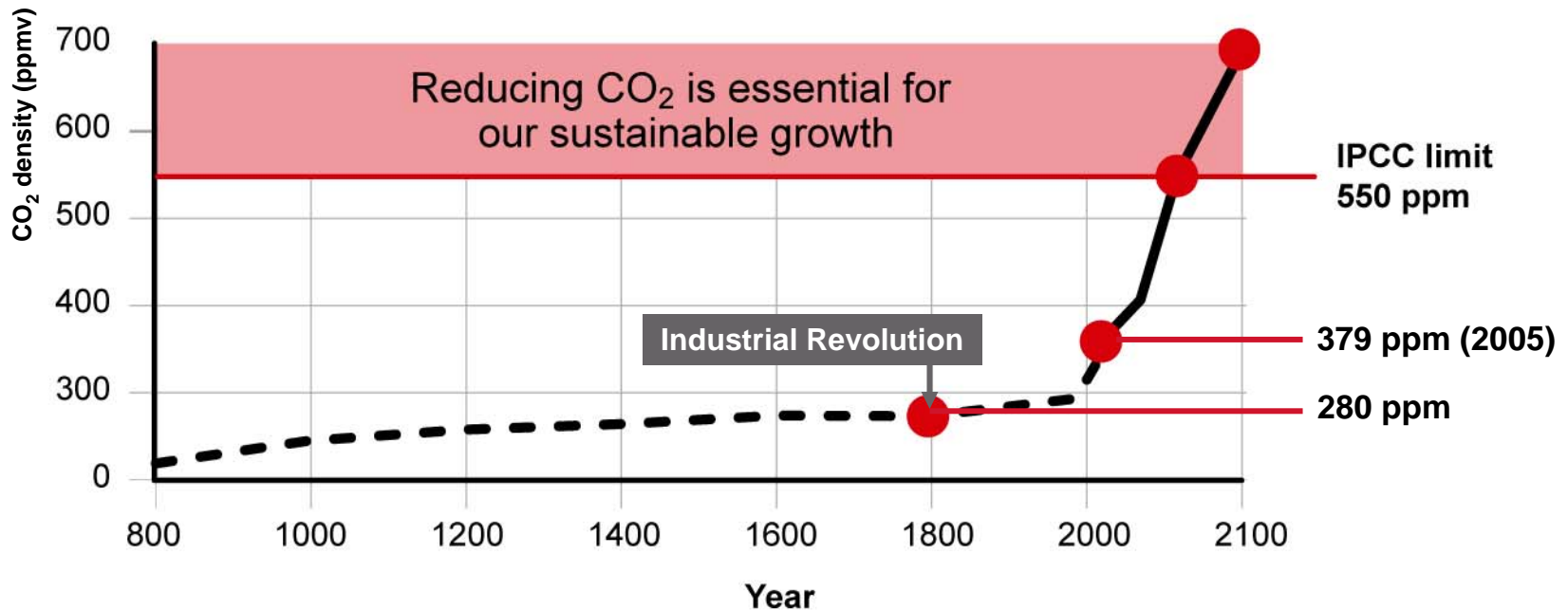

Source: IPCC report 2007

CO₂ emissions by sector

Breakdown of worldwide CO₂ emissions sources

Transport accounts for 23% of all man made CO₂ emissions.

Comprehensive CO₂ constraints are needed in each sector.

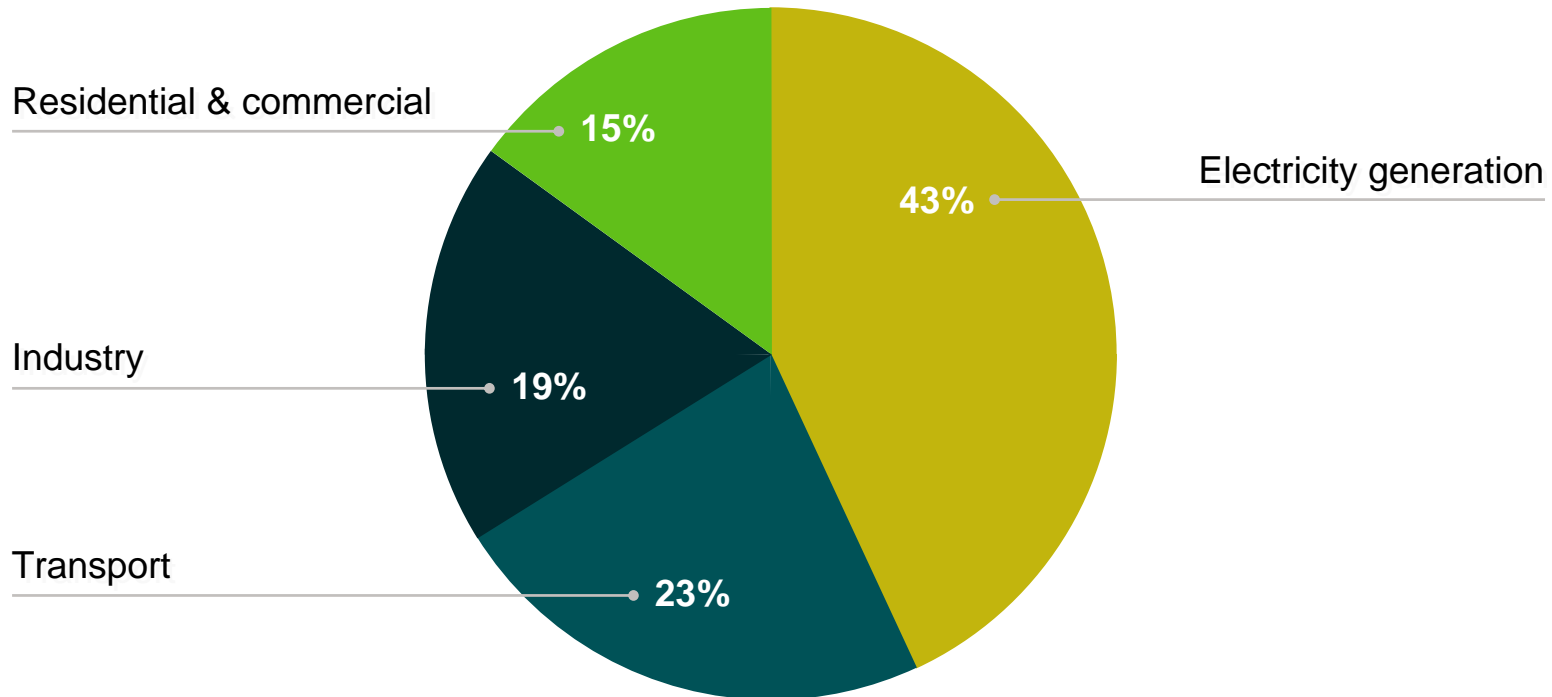

Source: IEA

Environmental initiatives must be underpinned by regulatory compliance

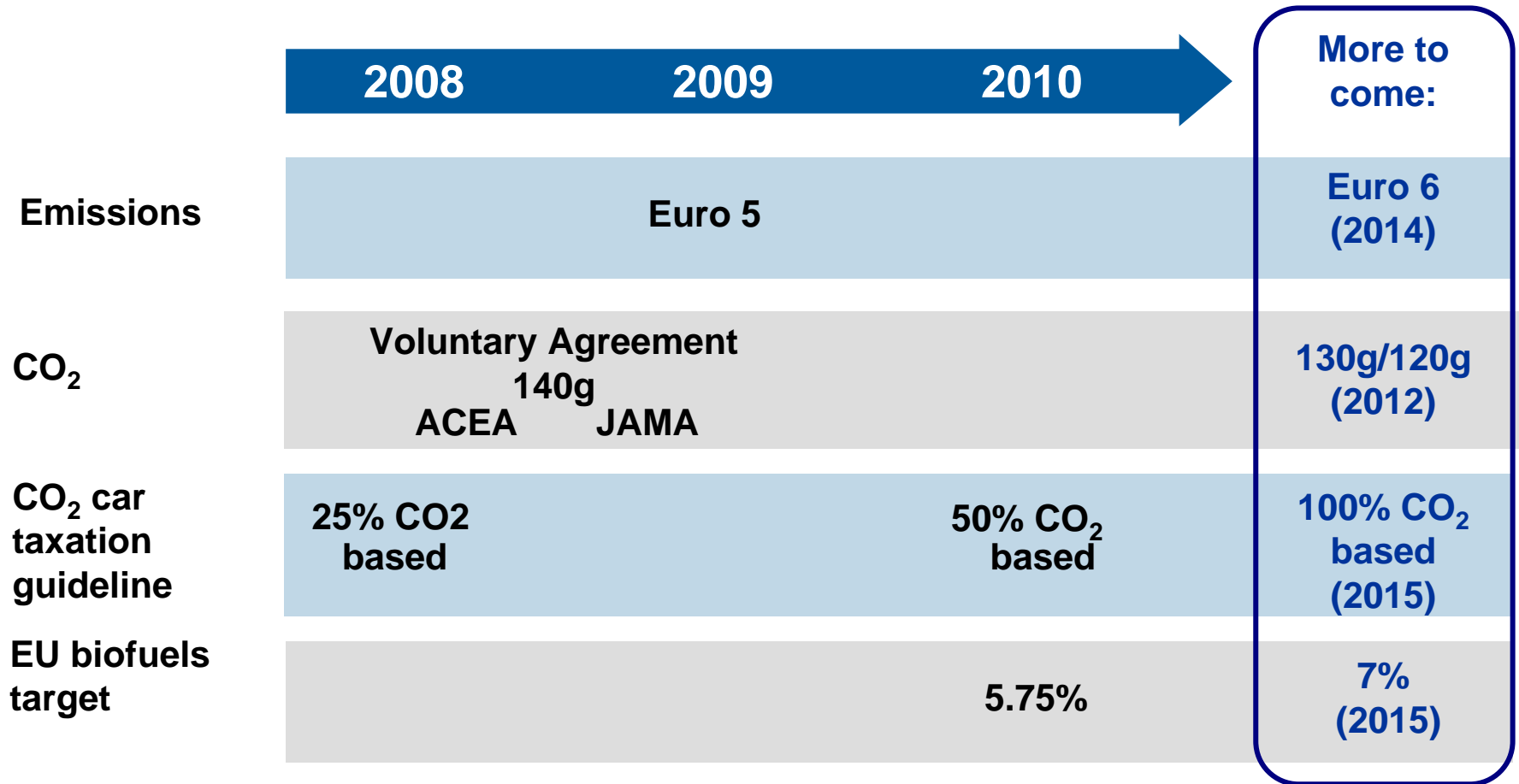

CO₂ – from voluntary commitment to legislation

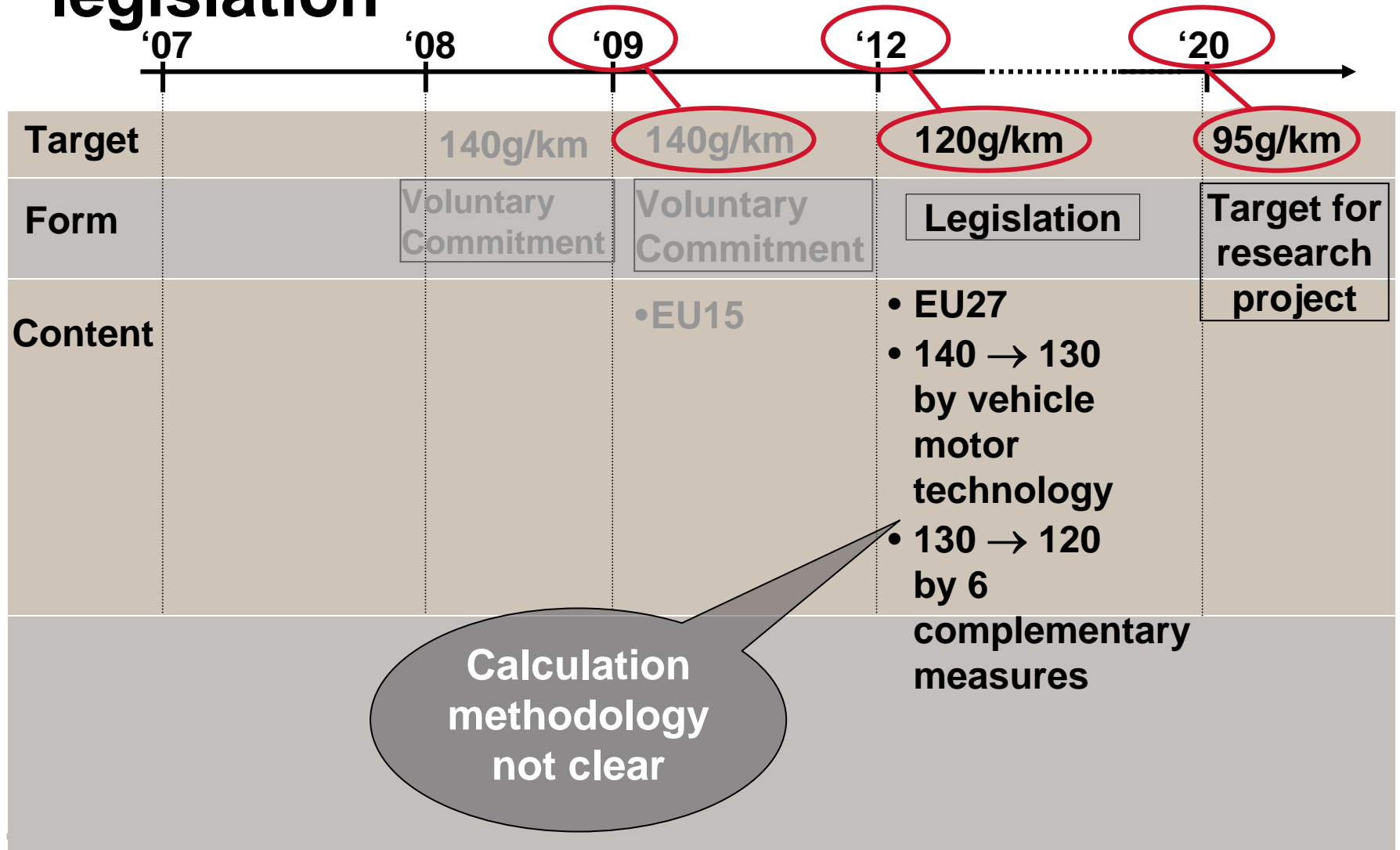

CO₂ reduction part of national legislation

Example: CO₂ taxation

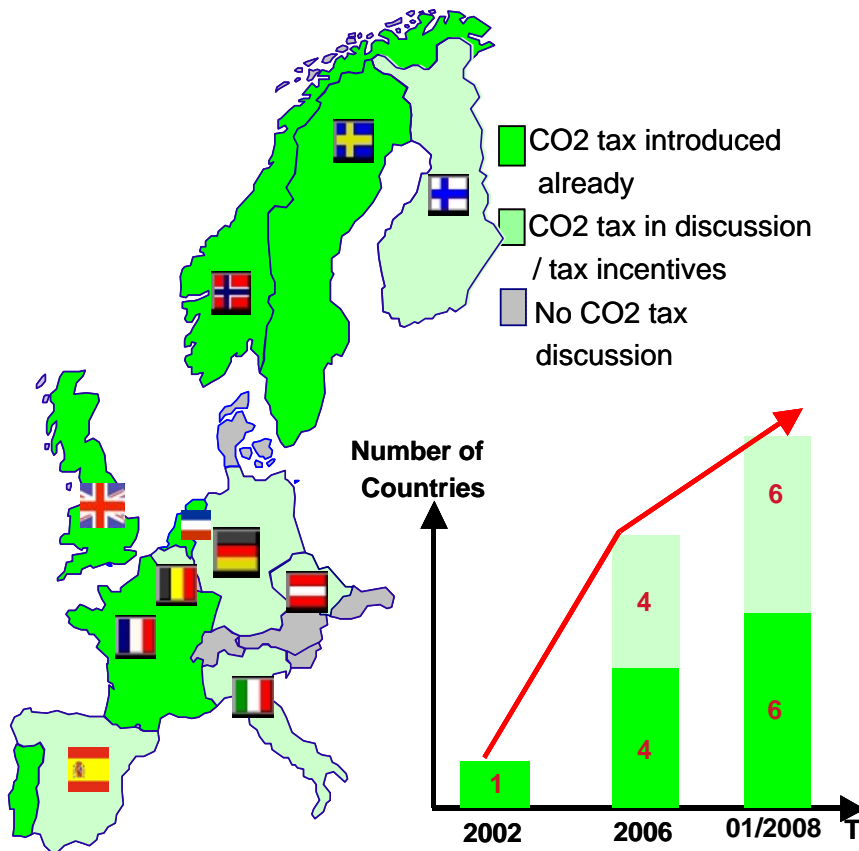

Example: CO₂ labelling

Brandstofverbruik en CO ₂ -uitstoot personenauto's		Plaats voorbehouden voor het logo van het merk (facultatieve melding)																					
Merk	X																						
Model	Y																						
Uitvoering	1,4																						
Brandstof	benzine																						
Verstelmingsbak	manuele																						
Brandstofverbruik gemeten volgens officiële testcyclus	6,2 liter/100km																						
CO₂-uitstoot gemeten volgens officiële testcyclus CO ₂ is het broeikasgas dat bij de wereldwijde klimaatverandering de belangrijkste rol speelt	148 g/km																						
Brandstofverbruik en CO₂-emissies vergeleken met het gemiddelde van alle modellen van benzinewagens (metals gemiddelde 7,4 l/100 km en 175 g/km CO ₂)																							
<table border="1"> <thead> <tr> <th>100</th> <th>130</th> <th>160</th> <th>190</th> <th>220</th> <th>250</th> <th>g/km CO₂</th> </tr> </thead> <tbody> <tr> <td>A</td> <td>B</td> <td>C</td> <td>D</td> <td>E</td> <td>F</td> <td>G</td> </tr> <tr> <td>4,2</td> <td>5,5</td> <td>6,7</td> <td>8</td> <td>9,3</td> <td>10,5</td> <td>U/100 km</td> </tr> </tbody> </table>			100	130	160	190	220	250	g/km CO ₂	A	B	C	D	E	F	G	4,2	5,5	6,7	8	9,3	10,5	U/100 km
100	130	160	190	220	250	g/km CO ₂																	
A	B	C	D	E	F	G																	
4,2	5,5	6,7	8	9,3	10,5	U/100 km																	
Jaar van toepassing																							
2011																							
Een gids betreffende het brandstofverbruik en de CO ₂ -uitstoot met gegevens voor alle modellen van nieuwe personenauto's is gratis verkrijgbaar in elk verkooppunt. Naast de brandstofefficiëntie van een auto zijn ook het rijgedrag en andere niet-technische factoren bepalend voor het brandstofverbruik en de CO ₂ -uitstoot van een auto. Een regelmatig en goed onderhoud van de wagen volgens de voorschriften van de constructeur bevordert ook een vermindering van het brandstofverbruik en van de CO ₂ -uitstoot.																							

Belgium

Consumer expectations changing

‘More than **two-thirds** of consumers globally believe that “*not harming the environment*” is the number one responsibility of big corporations’

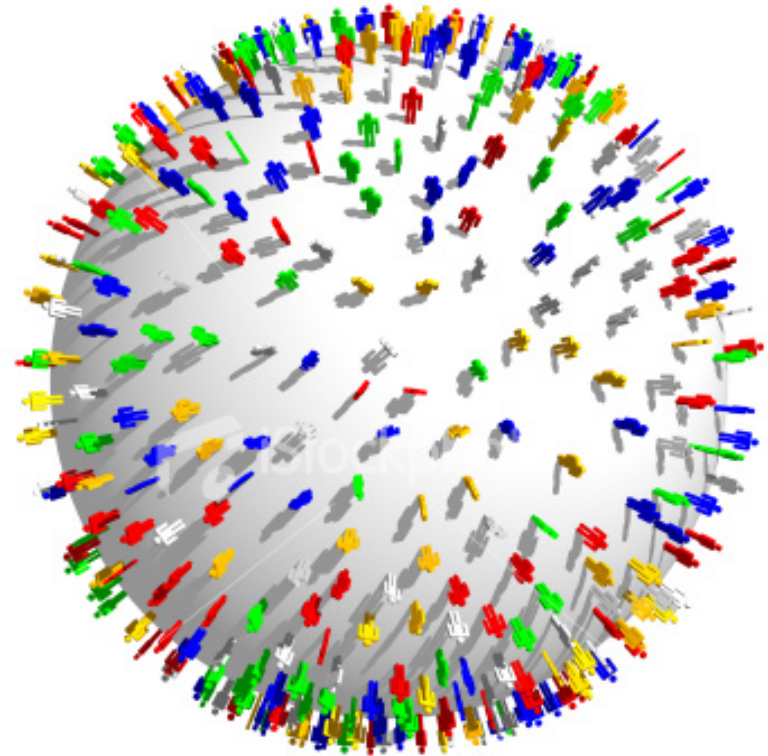

Source: Corporate Social Responsibility Monitor 2007

Our stance on Climate Change

- We accept man made global warming
- We recognize importance of target-setting
- We agree actions are needed to address environmental concerns without depleting resources for future generations



Today for Tomorrow
aim: zero emissions

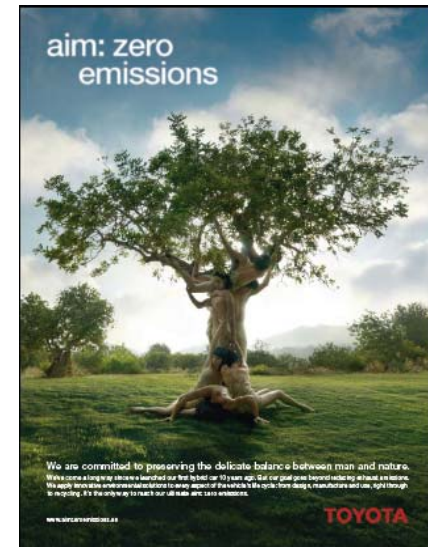

Our Energy / CO₂ Prioritization Strategy

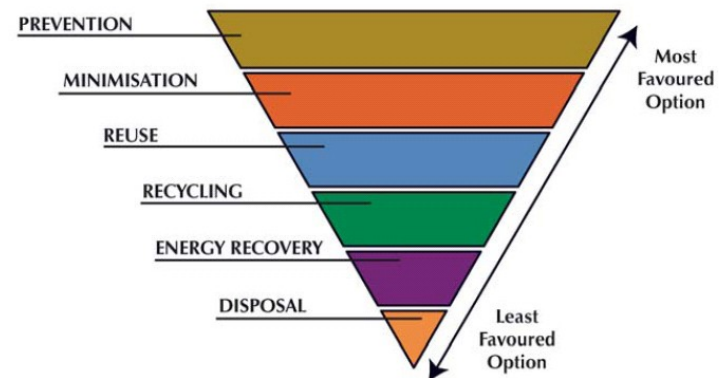
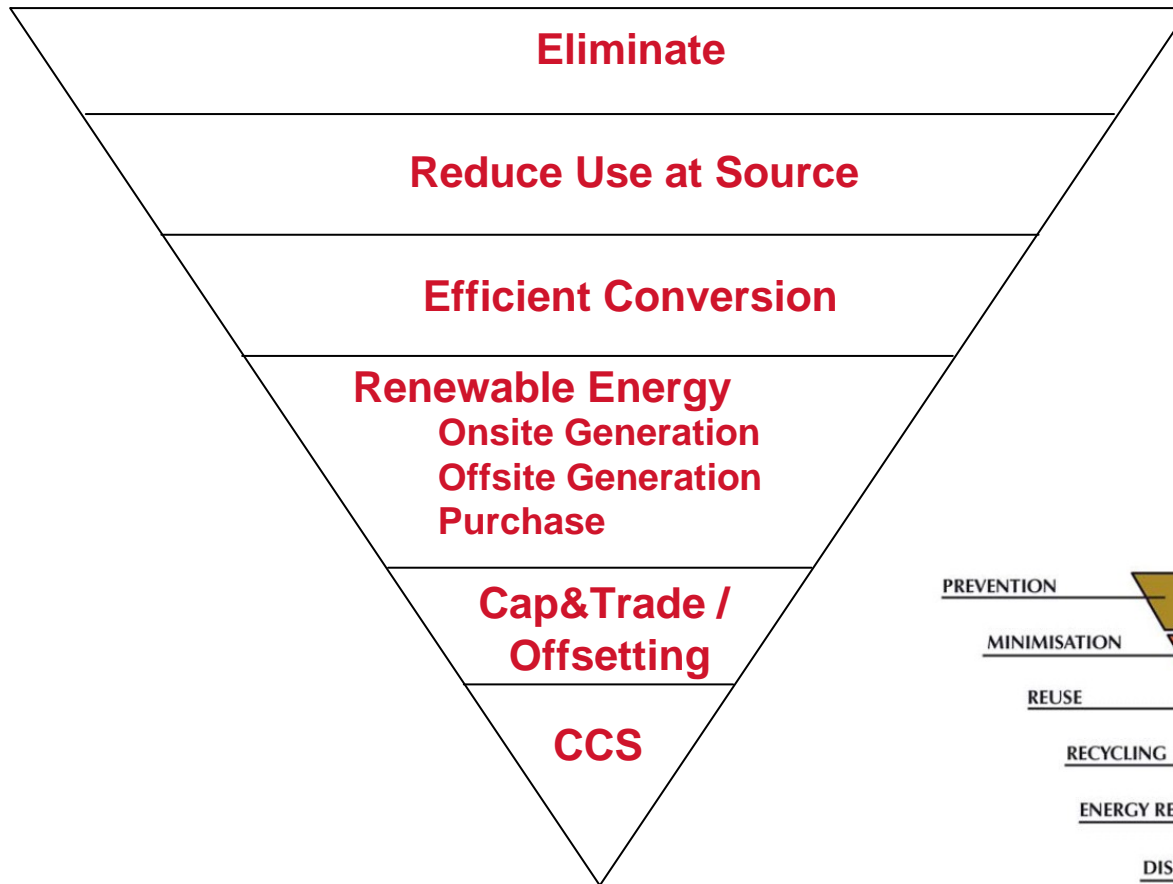

Same thinking: EU Waste hierarchy

Towards the ultimate 'eco-car' with hybrid as the platform

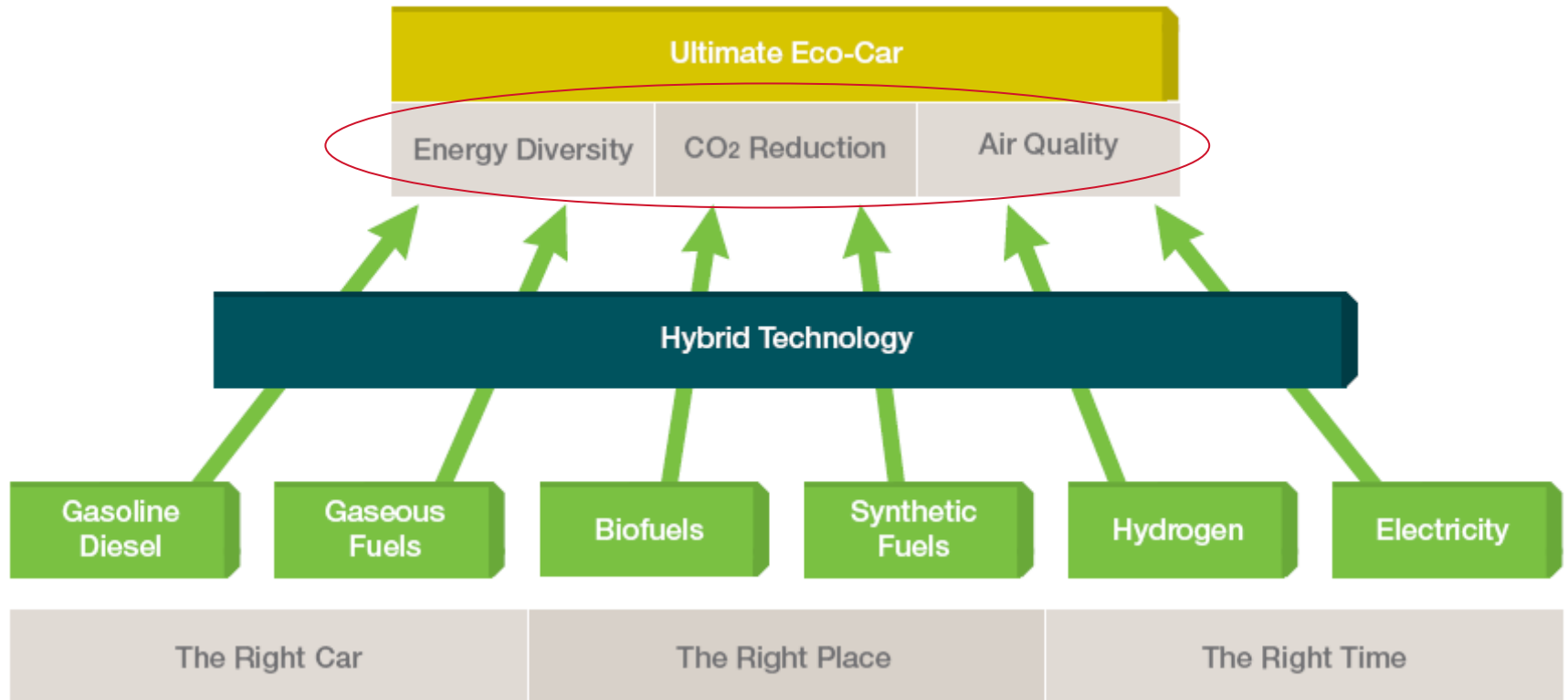

Source: **Toyota Motor Europe - Sustainability Report 2007**, p. 28

Progress towards low Exhaust Emissions

Development of Emission Standards in Europe, Japan and the USA

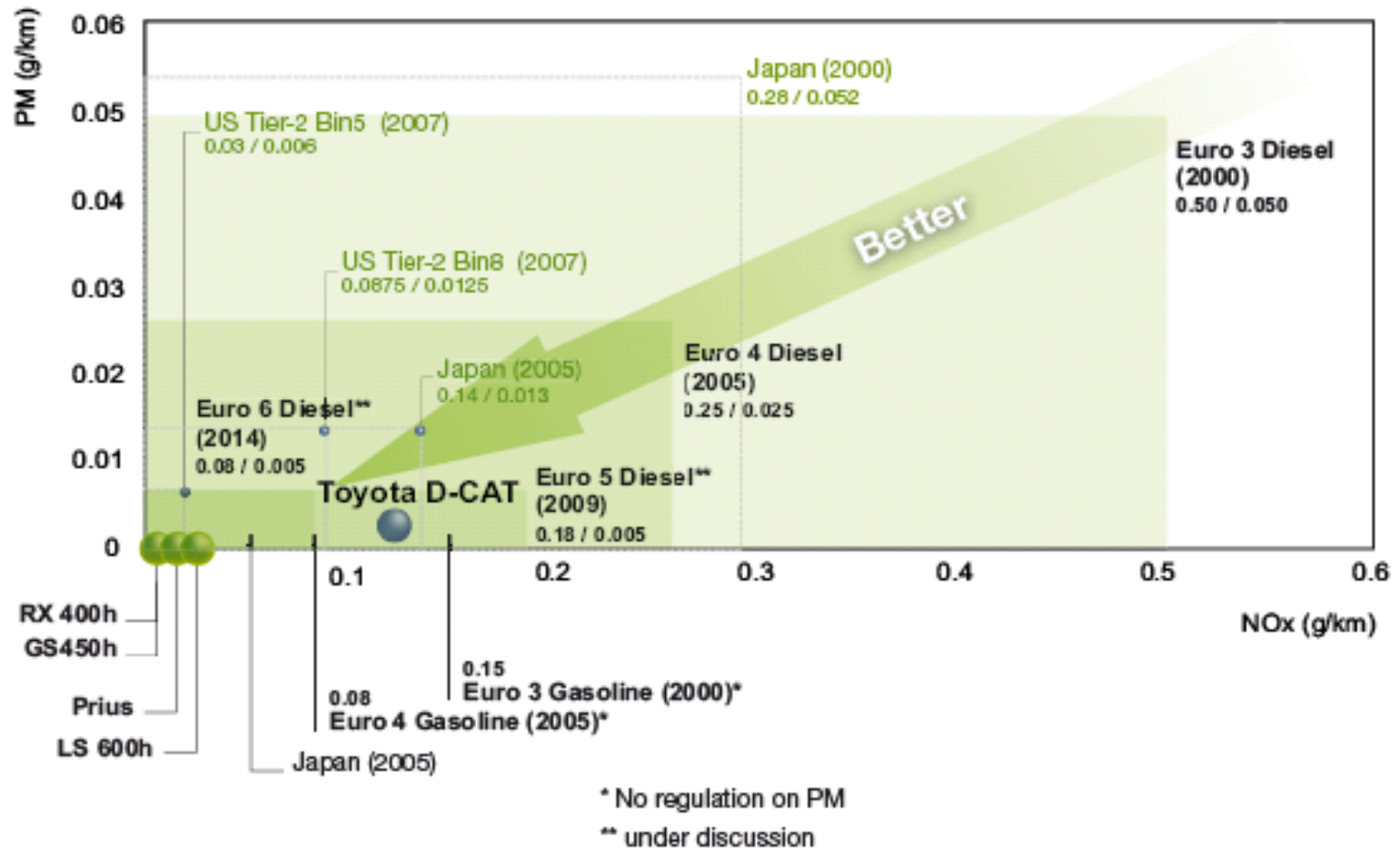

Evolution of Hybrid Units

Continuous improvements (KAIZEN) and the challenge to achieve higher performance with smaller and lighter units in other words, improved output density, is a key objective for hybrid development

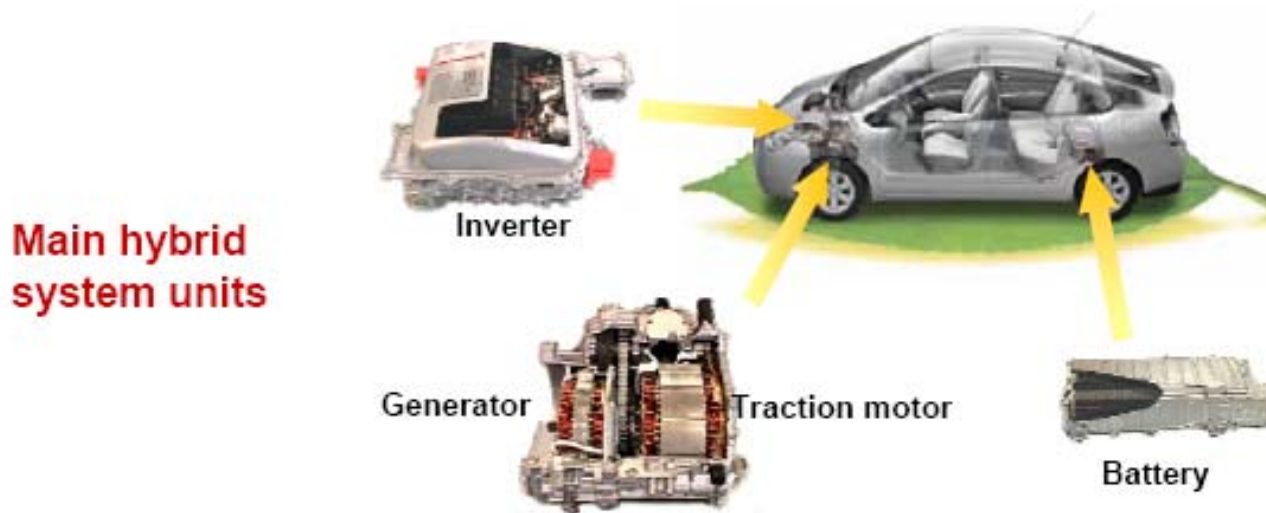

Motor

Unit for FWD vehicle

- RX400h
- Camry HV
- Estima HV

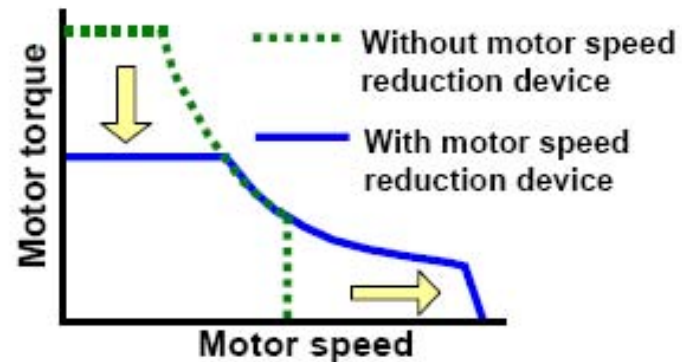

PRIUS

RX400h

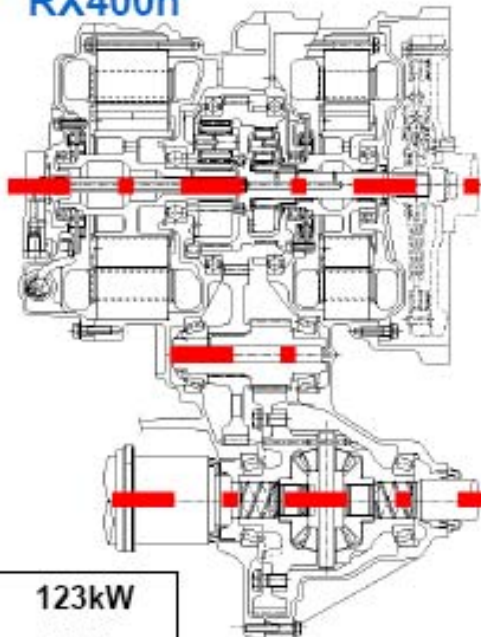
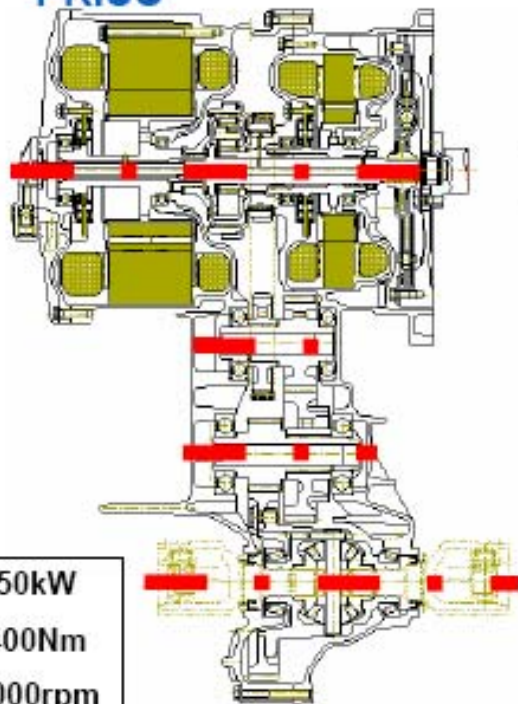

**Output
increase
to 250%,
same size**

50kW
400Nm
6000rpm

123kW
333Nm
12400rpm

Inverter / Power Control Unit

'97 Prius



'03 Prius



'05 RX400h



'06GS450h



'07LS600h

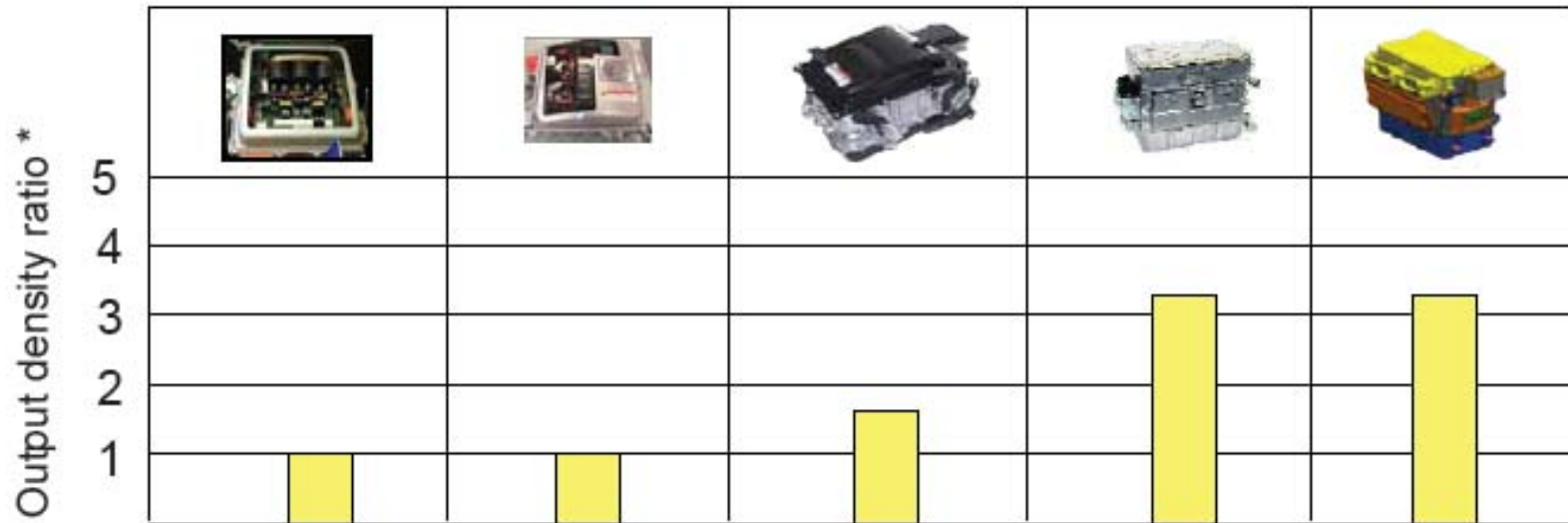

* Volumetric base

Inverter / Power Control Unit









GS450h vs RX400h:

Weight reduction -43%

Volume reduction -63%



Battery

	'97	'98	'99	'00	'01	'02	'03	'04	'05	'06	'07
HV		'97 Prius			'00 Prius			'03 Prius			
Battery module	Cylindrical			Prismatic			New prismatic resin case				
											
											
							New prismatic metal case '05 RX400h				
Battery pack											
											
							New				

Battery

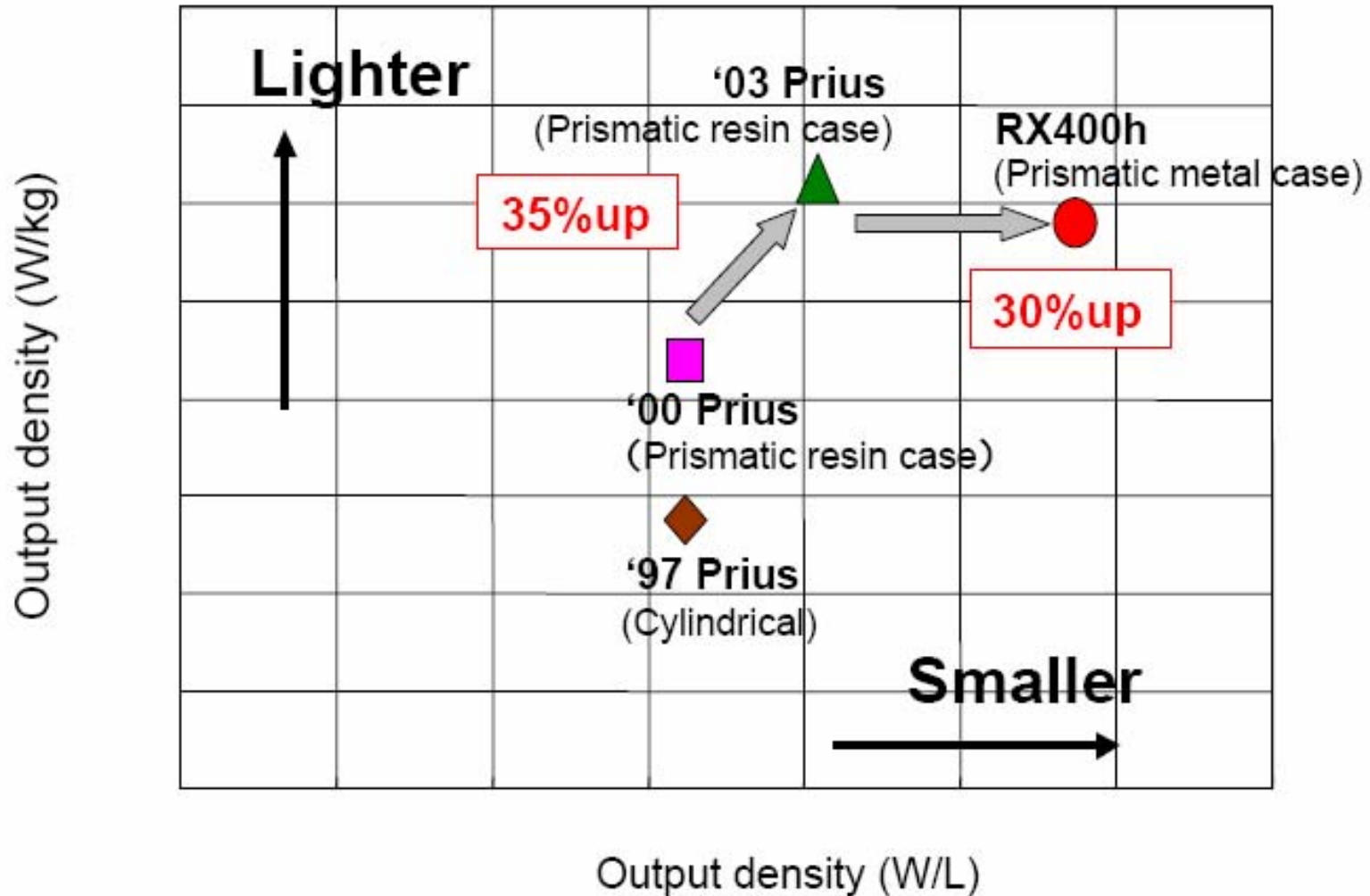

Plug-in Hybrid: Issues

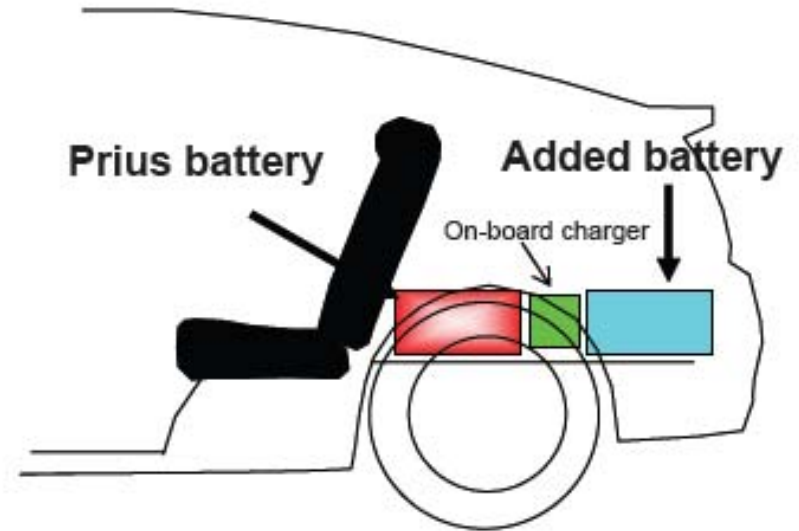
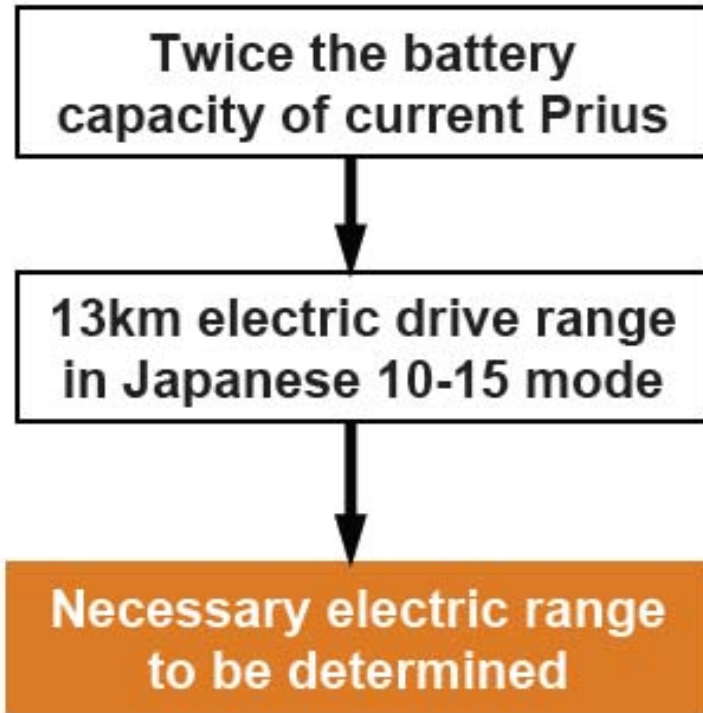

Battery innovation = Key for plug-in hybrid concept

Plug-in Hybrid Vehicle (PHV)



- Road testing in Europe since September 2007 in partnership with EDF
- Lithium-ion PHVs in Europe by 2010

Toyota D-CAT

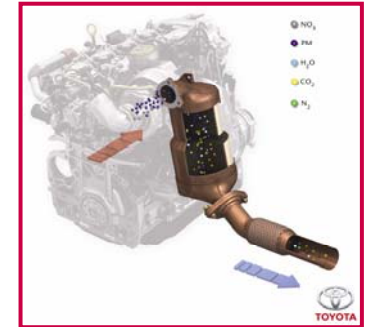
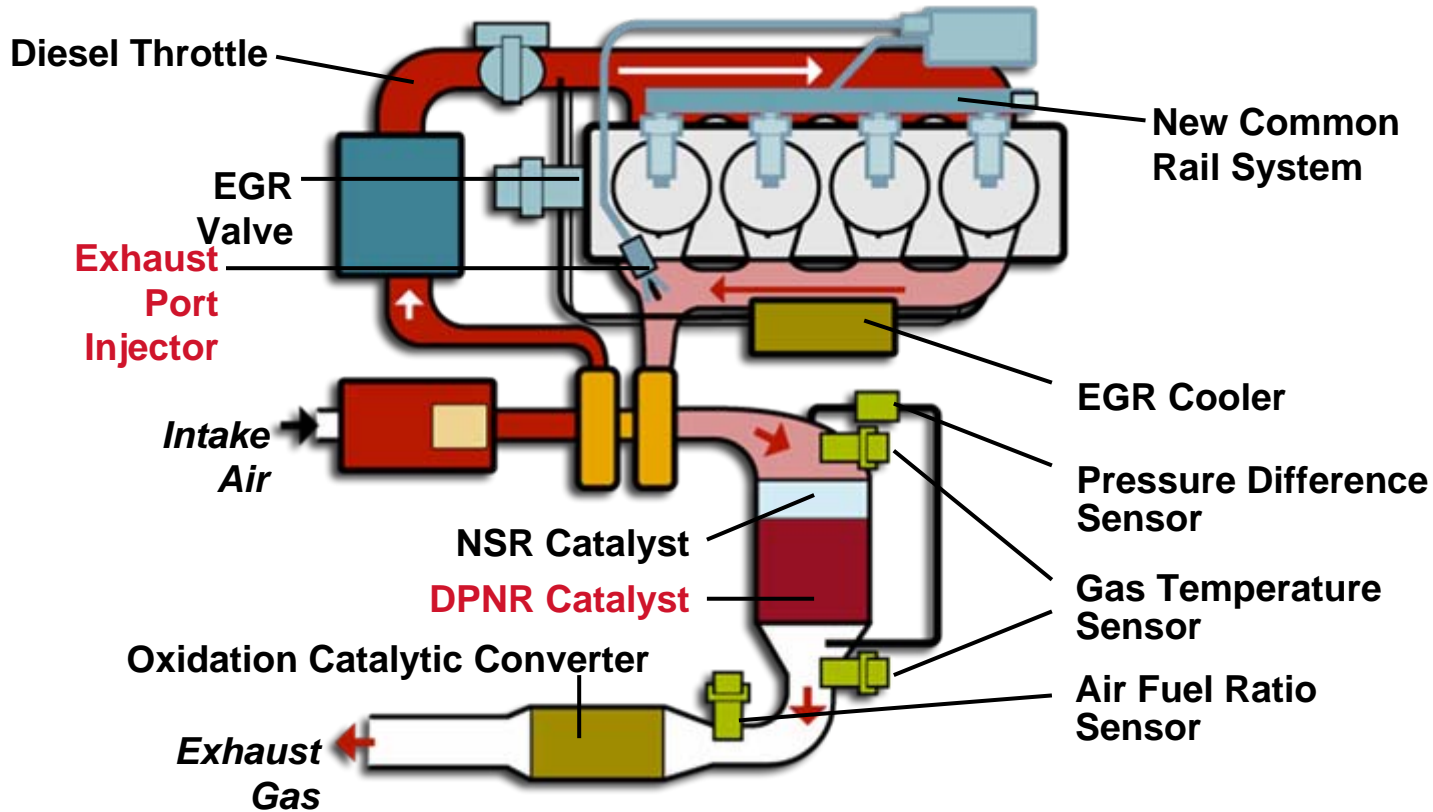

Toyota's Fuel Cell Technology

Prius



FINE-X

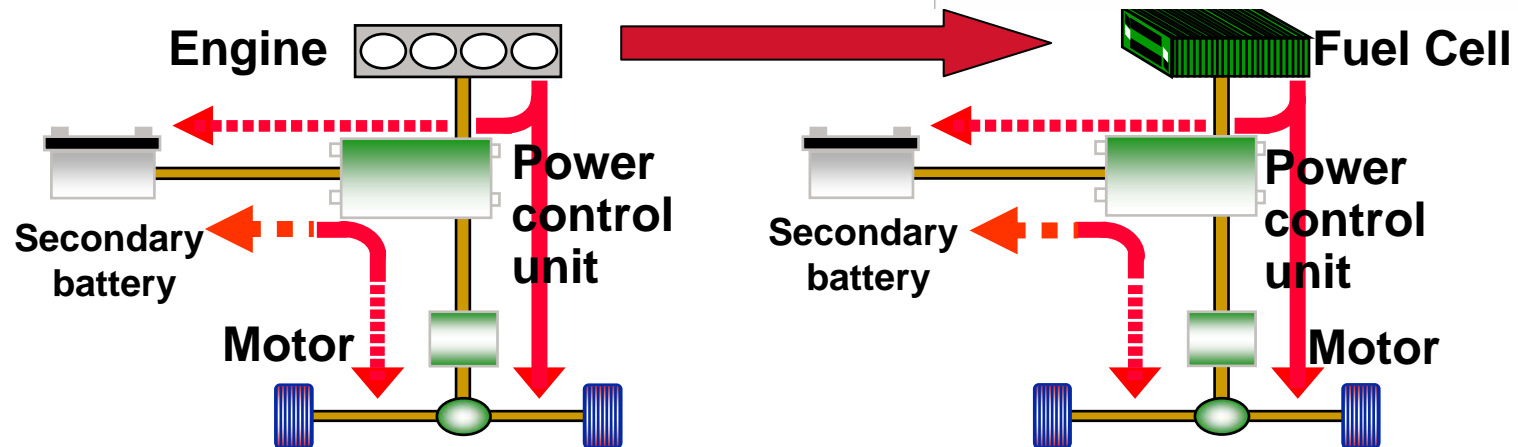

Challenges for fuel cell vehicles

Performance in very cold conditions



Startability test



- Achieve starting & driving under -30°C
- Range now proven at 560km on one tank

Personal Mobility for a New Traffic Environment: i-REAL



Biofuels – Toyota's stance



- Allow for 10% ethanol and 5% bio-diesel blending
- Need for clear consumer information and awareness to avoid confusion at the pump & possible problems
- Need for fuel quality standards on alternative fuels
- Flex Fuel Vehicles in certain markets (Brasil, USA)
- Preference is 2nd Generation: better overall CO₂ reduction

Biofuels development

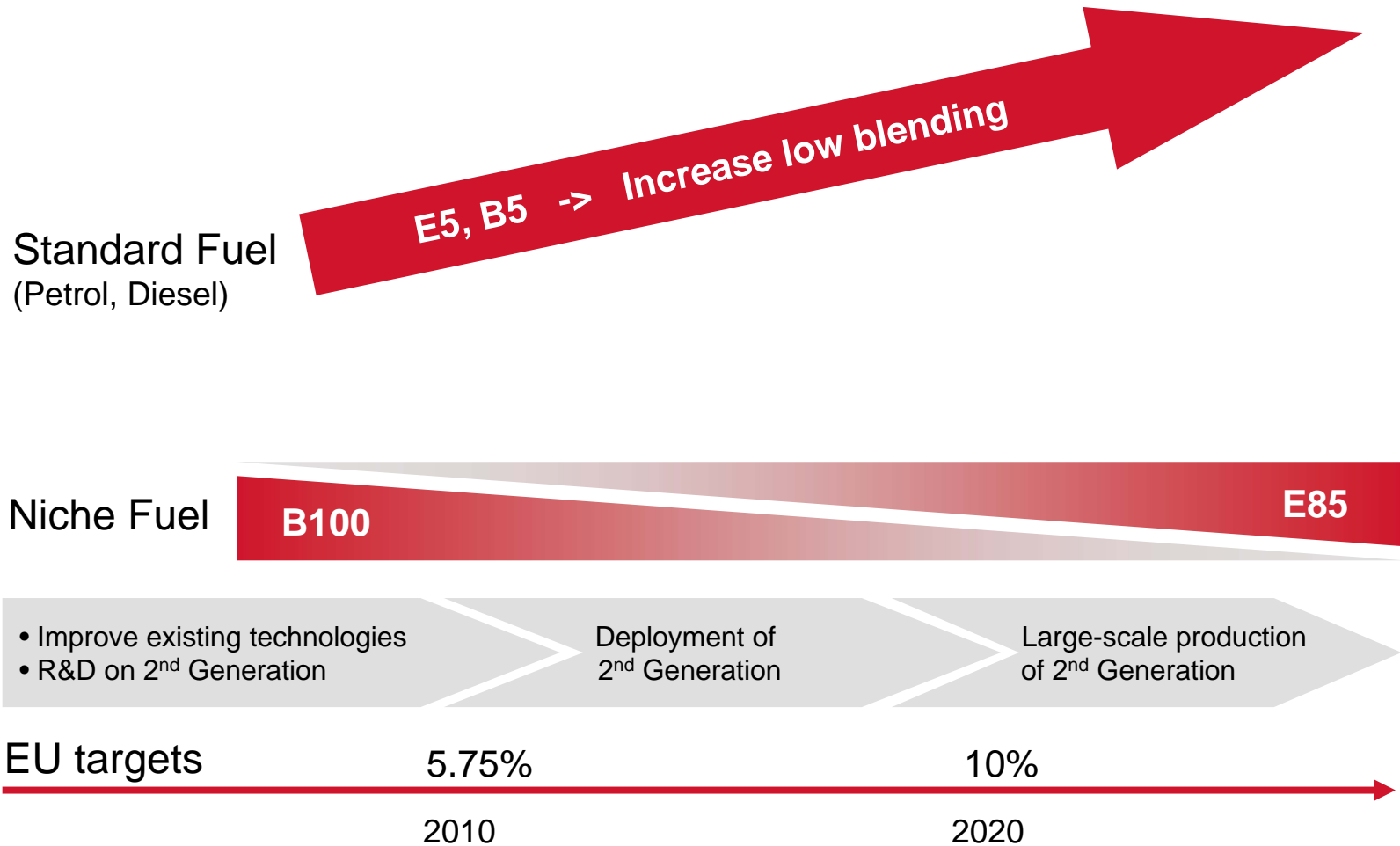

Towards the Ultimate 'Eco-Company' with EMS as the platform

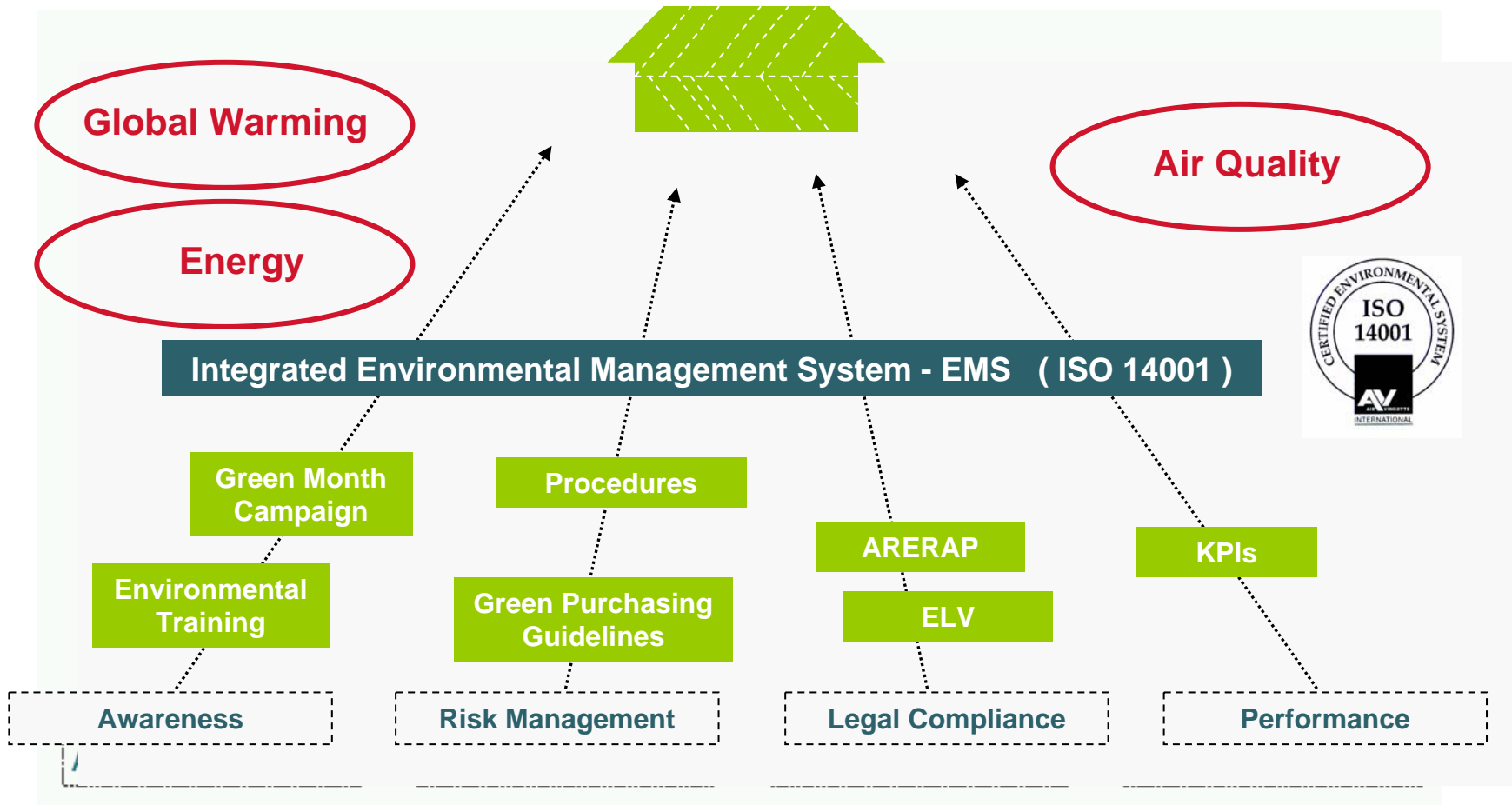

Sustainable plants: benchmark performance

Using natural resources whilst existing in harmony with natural surroundings



Energy use per vehicle produced has been reduced by 44 % since 2001

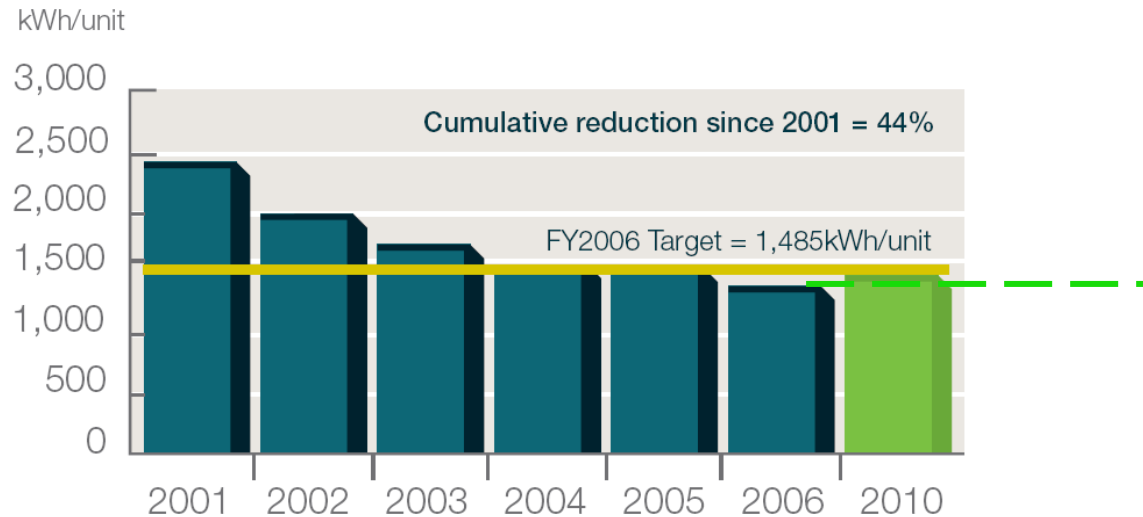

We are currently at 1,332 kWh/car

Consolidated Data						
Fiscal Year	2001	2002	2003	2004	2005	2006
Number of Plants Included	4	5	5	5	5	7
Data (kWh/unit)	2,424	1,949	1,697	1,560	1,536	1,332

'Greening' our network of European retailers



Our retailer vision in France

Support for EcoDriving

Gear Shift Indicator (manual transmission)



Indicates gear shift point for good fuel economy drive

Eco Drive Indicator (Automatic transmission, CVT)



ECO

Indicates good fuel economy condition

**Momentary FE
11.4km/L**

Indicates momentary fuel economy value



Driver education program

Summary

- More than 1 million Toyota and Lexus hybrid vehicles were sold during the last 10 years, mainly in the US, Japan and Europe.
- Toyota will continue and expand the development of hybrid vehicles and technology because hybrid is one of the important solutions for environmental and energy issues
- With plug-in HV technology Toyota develops today promising technology for the future, however innovative battery technology is required.

Thank you for your kind attention !

A large, leafy tree stands in a grassy field under a blue sky with scattered clouds. The trunk and lower branches of the tree are formed by several people, some sitting on the ground and others standing or lying on their backs, their bodies intertwined to create the structure of the tree. The scene is set in a natural, open landscape with other trees and hills in the background.

aim: zero emissions

We are committed to preserving the delicate balance between man and nature. We've come a long way since we launched our first hybrid car 10 years ago. But our goal goes beyond reducing exhaust emissions. We apply innovative environmental solutions to every aspect of the vehicle's life cycle, from design, manufacture and use, right through to recycling. It's the only way to reach our ultimate aim: zero emissions.

www.aimzeroemissions.eu

TOYOTA